

MCT6, MCT61, MCT62 Dual Phototransistor Optocouplers

Features

- Two isolated channels per package
- Two packages fit into a 16 lead DIP socket
- Choice of three current transfer ratios
- Underwriters Laboratory (U.L.) recognized File E90700

Applications

- AC Line/Digital Logic – Isolate high voltage transients
- Digital Logic/Digital Logic – Eliminate spurious grounds
- Digital Logic/AC Triac Control – Isolate high voltage transients
- Twisted pair line receiver – Eliminate ground loop feedthrough
- Telephone/Telegraph line receiver – Isolate high voltage transients
- High Frequency Power Supply Feedback Control – Maintain floating grounds and transients
- Relay contact monitor – Isolate floating grounds and transients
- Power supply monitor – Isolate transients

Description

The MCT6X Optocouplers have two channels for density applications. For four channel applications, two-packages fit into a standard 16-pin DIP socket. Each channel is an NPN silicon planar phototransistor optically coupled to a gallium arsenide infrared emitting diode.

Schematic

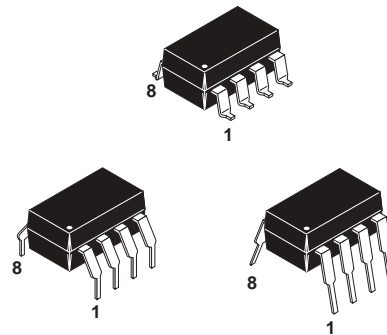
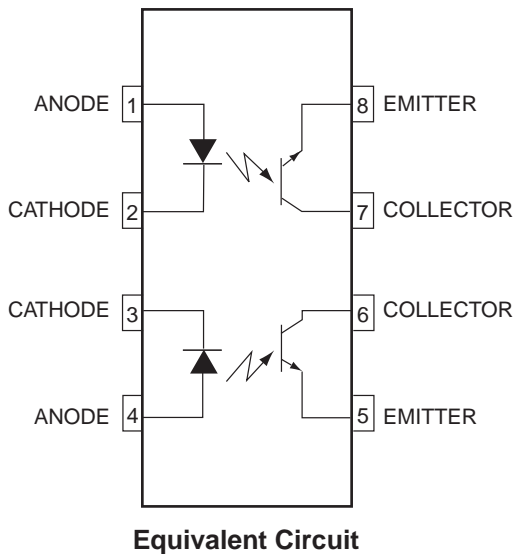

Absolute Maximum Ratings

Rating	Symbol	Value	Unit
EMITTER (Each channel)			
Forward Current – Continuous	I_F	60	mA
Forward Current – Peak (PW = 1 μ s, 300pps)	$I_F(pk)$	3	A
Reverse Voltage	V_R	3.0	V
LED Power Dissipation @ $T_A = 25^\circ\text{C}$ Derate above 25 $^\circ\text{C}$ (Total Input)	P_D	100 1.3	mW mW/ $^\circ\text{C}$
DETECTOR (Each channel)			
Collector Current – Continuous	I_C	30	mA
Detector Power Dissipation @ $T_A = 25^\circ\text{C}$ Derate above 25 $^\circ\text{C}$	P_D	150 2.0	mW mW/ $^\circ\text{C}$
TOTAL DEVICE			
Storage Temperature	T_{STG}	-55 to +150	$^\circ\text{C}$
Operating Temperature	T_{OPR}	-55 to +100	$^\circ\text{C}$
Lead Solder Temperature (wave solder)	T_{SOL}	250 for 10 sec	$^\circ\text{C}$
Total Device Power Dissipation @ $T_A = 25^\circ\text{C}$ Derate above 25 $^\circ\text{C}$	P_D	400 5.33	mW mW/ $^\circ\text{C}$

Electrical Characteristics ($T_A = 25^\circ\text{C}$ unless otherwise specified)

Parameter	Test Conditions	Symbol	Min.	Typ.*	Max.	Units
INDIVIDUAL COMPONENT CHARACTERISTICS						
Emitter						
Input Forward Voltage	$I_F = 20\text{mA}$	V_F		1.2	1.5	V
Reverse Voltage	$I_R = 10\mu\text{A}$	V_R	3.0	25		V
Reverse Current	$V_R = 5\text{V}$	I_R		0.001	10	μA
Junction Capacitance	$V_F = 0\text{V}$, $f = 1\text{MHz}$	C_J		50		pF
Detector						
Collector-Emitter Breakdown Voltage	$I_C = 1.0\text{mA}$, $I_F = 0$	BV_{CEO}	30	85		V
Emitter-Collector Breakdown Voltage	$I_E = 100\mu\text{A}$, $I_F = 0$	BV_{ECO}	6	13		V
Collector-Emitter Dark Current	$V_{CE} = 10\text{V}$, $I_F = 0$	I_{CEO}		5	100	nA
Capacitance	$V_{CE} = 0\text{V}$, $f = 1\text{MHz}$	C_{CE}		8		pF

AC Characteristic	Test Conditions	Symbol	Min	Typ*	Max	Units
TRANSFER CHARACTERISTICS						
Switching Characteristics						
Non-Saturated Turn-on Time	$R_L = 100\Omega$, $I_C = 2\text{mA}$, $V_{CC} = 10\text{V}$	t_{on}		2.4		μs
Non-Saturated Turn-off Time		t_{off}		2.4		μs

All typicals at $T_A = 25^\circ\text{C}$

Electrical Characteristics ($T_A = 25^\circ\text{C}$) (Continued)

DC Characteristic	Test Conditions	Symbol	Min	Typ*	Max	Units
TRANSFER CHARACTERISTICS						
Current Transfer Ratio, Collector-Emitter						
MCT6	$I_F = 10\text{mA}$, $V_{CE} = 10\text{V}$	CTR	20			%
MCT61	$I_F = 5\text{mA}$, $V_{CE} = 5\text{V}$		50			
MCT62			100			
Saturation Voltage	$I_F = 16\text{mA}$, $I_C = 2\text{mA}$	$V_{CE(sat)}$		0.15	0.40	V

Characteristic	Test Conditions	Symbol	Min	Typ*	Max	Units
ISOLATION CHARACTERISTICS						
Input-Output Isolation Voltage	$I_{I-O} \leq 1\mu\text{A}$, $t = 1\text{min.}$	V_{ISO}	5300			Vac(rms)
Isolation Resistance	$V_{I-O} = 500\text{VDC}$	R_{ISO}	10^{11}			Ω
Input-Output Isolation Voltage	$f = 1\text{MHz}$	C_{ISO}		0.5		pF

* All typicals at $T_A = 25^\circ\text{C}$

Typical Performance Curves

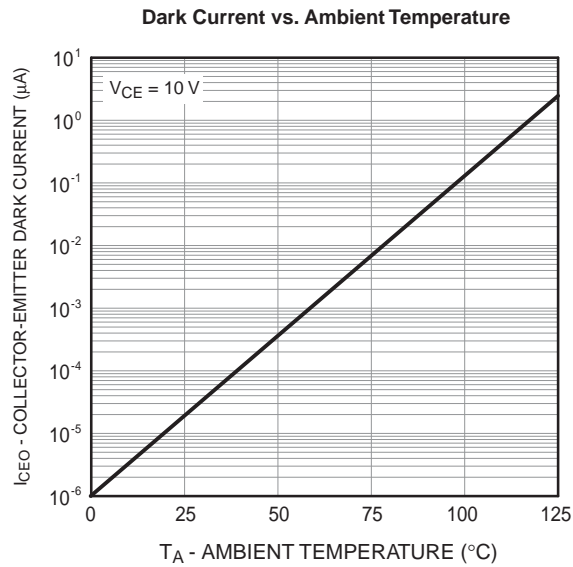
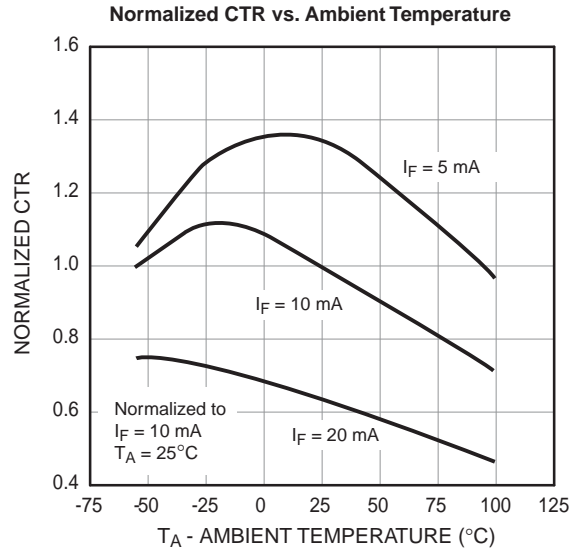
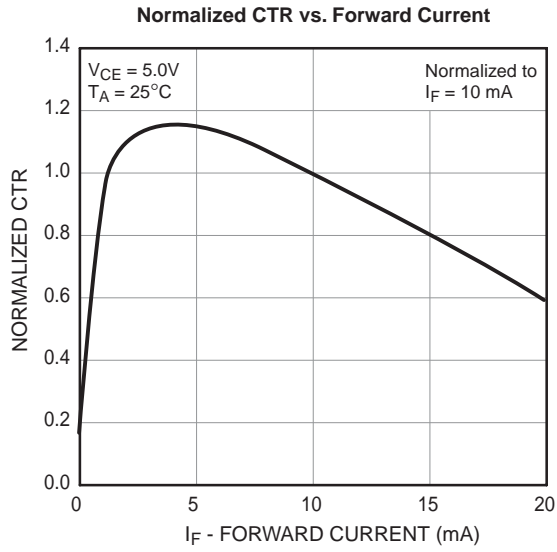

Typical Performance Curves (Continued)

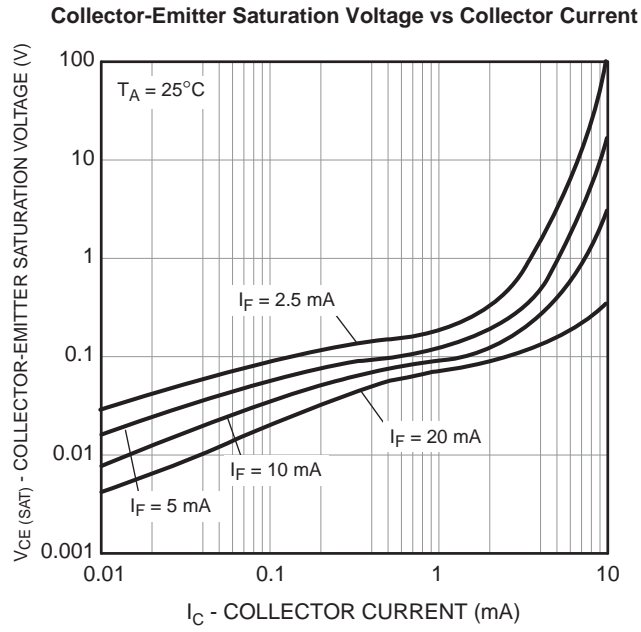
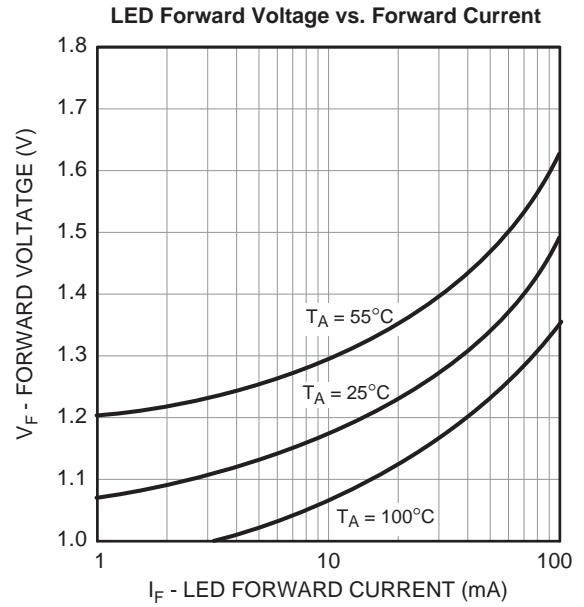
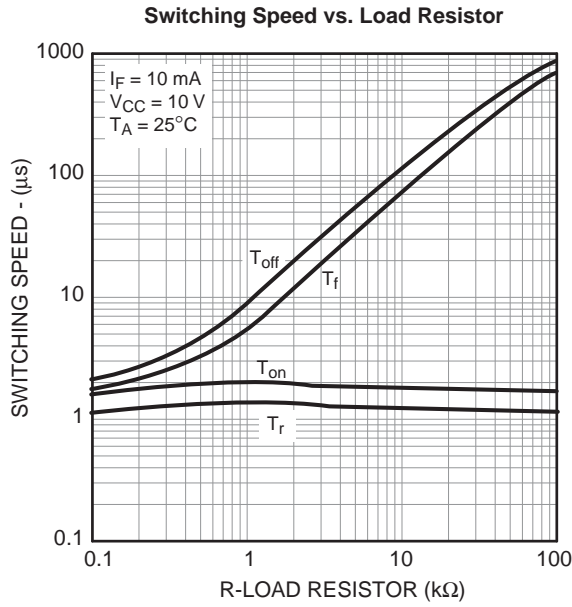

Package Dimensions

Through Hole

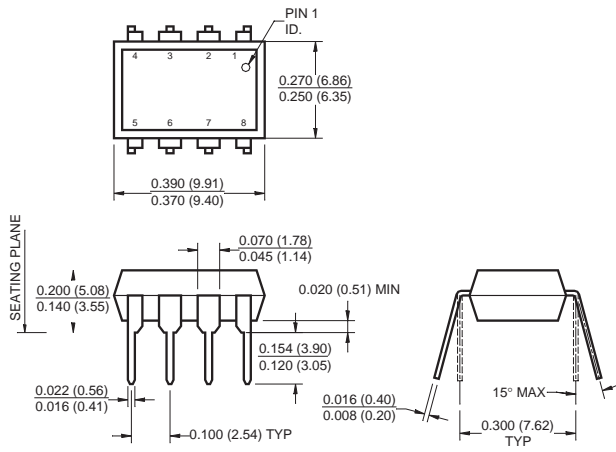

Surface Mount

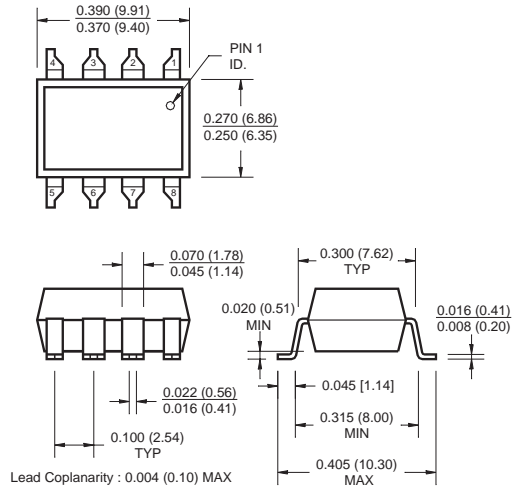

0.4" Lead Spacing

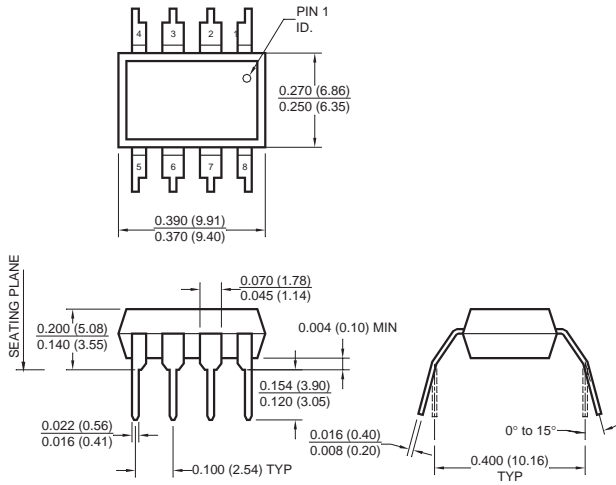

Recommend Pad Layout for Surface Mount Leadform

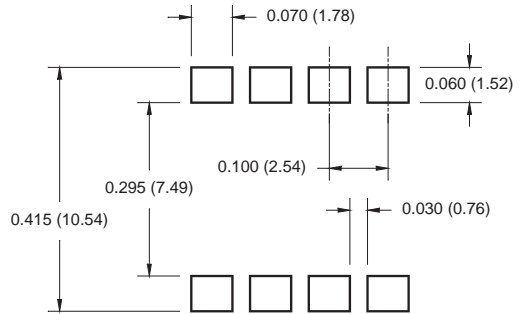

Note:

All dimensions are in inches (millimeters)

Ordering Information

Option	Order Entry Identifier	Description
S	.S	Surface Mount Lead Bend
SD	.SD	Surface Mount; Tape and Reel
W	.W	0.4" Lead Spacing

Marking Information

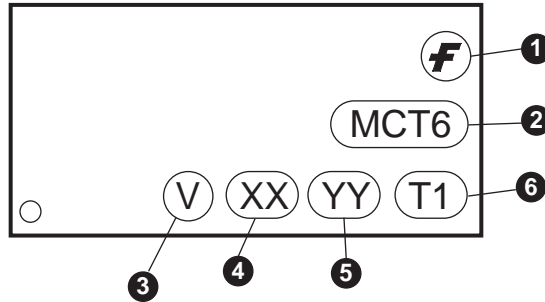

Definitions	
1	Fairchild logo
2	Device number
3	VDE mark (Note: Only appears on parts ordered with VDE option – See order entry table)
4	Two digit year code, e.g., '03'
5	Two digit work week ranging from '01' to '53'
6	Assembly package code

Carrier Tape Specifications

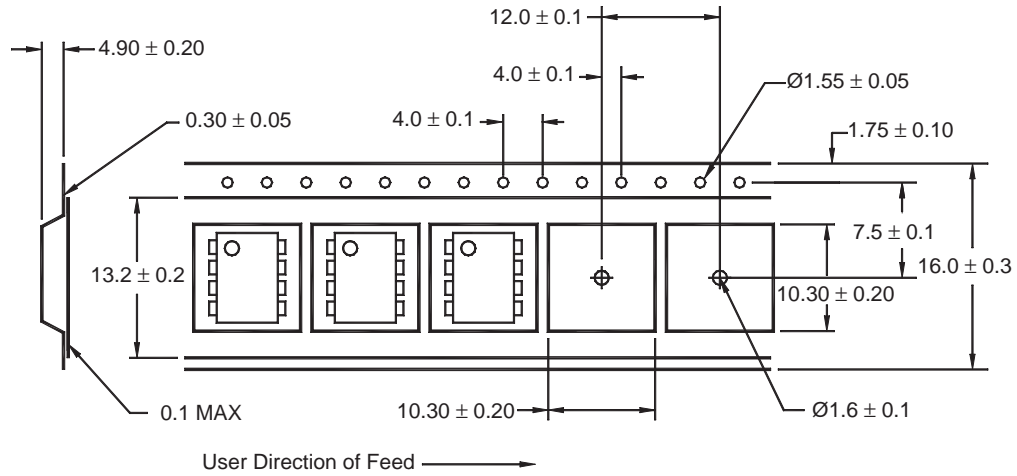

Note:
All dimensions are in inches (millimeters)

Reflow Profile

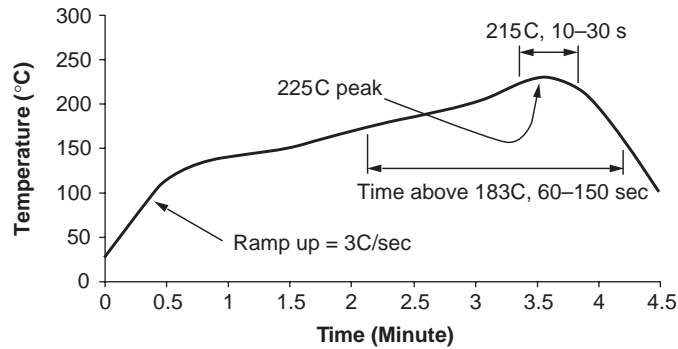

- Peak reflow temperature: 225C (package surface temperature)
- Time of temperature higher than 183C for 60-150 seconds
- One time soldering reflow is recommended

TRADEMARKS

The following are registered and unregistered trademarks Fairchild Semiconductor owns or is authorized to use and is not intended to be an exhaustive list of all such trademarks.

ACEx™	FAST®	ISOPLANAR™	PowerSaver™	SuperSOT™-6
ActiveArray™	FASTr™	LittleFET™	PowerTrench®	SuperSOT™-8
Bottomless™	FPST™	MICROCOUPLER™	QFET®	SyncFET™
Build it Now™	FRFET™	MicroFET™	QS™	TCM™
CoolFET™	GlobalOptoisolator™	MicroPak™	QT Optoelectronics™	TinyLogic®
CROSSVOLT™	GTO™	MICROWIRE™	Quiet Series™	TINYOPTO™
DOME™	HiSeC™	MSX™	RapidConfigure™	TruTranslation™
EcoSPARK™	I ² C™	MSXPro™	RapidConnect™	UHC™
E ² CMOS™	i-Lo™	OCX™	μSerDes™	UltraFET®
EnSigna™	ImpliedDisconnect™	OCXPro™	ScalarPump™	UniFET™
FACT™	IntelliMAX™	OPTOLOGIC®	SILENT SWITCHER®	VCX™
FACT Quiet Series™		OPTOPLANAR™	SMART START™	Wire™
Across the board. Around the world.™		PACMAN™	SPM™	
The Power Franchise®		POP™	Stealth™	
Programmable Active Droop™		Power247™	SuperFET™	
		PowerEdge™	SuperSOT™-3	

DISCLAIMER

FAIRCHILD SEMICONDUCTOR RESERVES THE RIGHT TO MAKE CHANGES WITHOUT FURTHER NOTICE TO ANY PRODUCTS HEREIN TO IMPROVE RELIABILITY, FUNCTION OR DESIGN. FAIRCHILD DOES NOT ASSUME ANY LIABILITY ARISING OUT OF THE APPLICATION OR USE OF ANY PRODUCT OR CIRCUIT DESCRIBED HEREIN; NEITHER DOES IT CONVEY ANY LICENSE UNDER ITS PATENT RIGHTS, NOR THE RIGHTS OF OTHERS.

LIFE SUPPORT POLICY

FAIRCHILD'S PRODUCTS ARE NOT AUTHORIZED FOR USE AS CRITICAL COMPONENTS IN LIFE SUPPORT DEVICES OR SYSTEMS WITHOUT THE EXPRESS WRITTEN APPROVAL OF FAIRCHILD SEMICONDUCTOR CORPORATION. As used herein:

1. Life support devices or systems are devices or systems which, (a) are intended for surgical implant into the body, or (b) support or sustain life, or (c) whose failure to perform when properly used in accordance with instructions for use provided in the labeling, can be reasonably expected to result in significant injury to the user.
2. A critical component is any component of a life support device or system whose failure to perform can be reasonably expected to cause the failure of the life support device or system, or to affect its safety or effectiveness.

PRODUCT STATUS DEFINITIONS

Definition of Terms

Datasheet Identification	Product Status	Definition
Advance Information	Formative or In Design	This datasheet contains the design specifications for product development. Specifications may change in any manner without notice.
Preliminary	First Production	This datasheet contains preliminary data, and supplementary data will be published at a later date. Fairchild Semiconductor reserves the right to make changes at any time without notice in order to improve design.
No Identification Needed	Full Production	This datasheet contains final specifications. Fairchild Semiconductor reserves the right to make changes at any time without notice in order to improve design.
Obsolete	Not In Production	This datasheet contains specifications on a product that has been discontinued by Fairchild semiconductor. The datasheet is printed for reference information only.

Rev. 118